

TPNCT-MT171(CT-Operated from 100 to 2000amp)

A three-phase active energy meter for household belongs to a new generation of Iskraemeco meters. It gives advantages to all users in the process: an installer, a maintenance engineer, a service engineer, a readout operator and a final user. The meter is approved and manufactured in compliance with the IEC 62052-1, IEC 62053-12 (IEC 61036) standards, and ISO 9001 and designed according to even higher internal Iskraemeco standards, achieved on experiences from more than 50 years of meter manufacturing and 50 Millions meters on the field installed around the globe.

Ofgem Approved
for Billing Purposes



	Active power
	Single or double direction
	Multi-rate registration
	Multiphasing
	Data display
	Impulse output (KWh)

- Fast and easy installation procedure, indications of correct connection
- Smaller dimensions for overall cost reduction of the meter site.
- Multi-phasing connection (all in one: single and poly-phase meter)
- Universal current terminal for all type of wires
- Indications of operational status
- Very high EMC immunity
- Communication optical port for semi-automatic meter reading

TPNCT-MT171

CT Operated 3phase Digital (LCD) Meter

FUNCTIONAL AND TECHNICAL DATA

MT171 is a poly-phase meter for residential and small commercial users, for revenue measuring of active power in four or three wire systems.

Measuring and registration: Standard (as a mechanical meter).

- Other options: – Double direction
- Always positive (absolute)

Accuracy/calibration: Due to the long-term stability there is no need for recalibration in meters life-time.

Indications:

- LED 1 (red):** kWh impulses (k=1000 imp/kWh)
- Illuminated:** meter is powered, no load current,
- Pulsating:** load current is higher than starting value,
- Not illuminated:** meter is not powered

Communication: Opto-port (IEC 62056 – 21): for local meter reading and programming.

Tamper proof features (optional): Meter detects main cover and terminal cover opening and records it in log-book .

Multi-phasing metering operation: meter can be connected as single, double or three-phase meter.

Multi-rate registration (optional): External tariff switching.
Programmable number of rates (1.... 4 rates)

Local metering data display (LCD):

- Automatic Scroll mode
 - Manual scroll (by button)
 - Programmable data set and sequence
- Data codification (only for optional extended-size LCD):
- EDIS (DIN 43 863 -3)
 - Defined by user
- LCD back-light: optional

Current terminals: Universal clamping type for all types of wires (D= 9,5mm).

Enclosure: Polycarbonate, Self – extinguish;

Protection against water and dust: IP 53

Accuracy class 2
Rated current I_n5, 10, 15, 40 A
Max. current I_{max} 120 A
Min. current 0.05 I_n
Starting current 0.004 I_b
Reference voltage U_n3 x 230/400 V
Voltage range 0.8 U_n ... 1.15 U_n
Reference frequency 50 Hz
Operating temp. range -25° C ... +60° C
Extended temp. range -40° C ... +70° C
Storage temperature -40° C ... +85° C
Current circuit burden <0.5 VA
Voltage circuit burden <1 W / 10 VA
Dielectric strength 4 kV, 50 Hz, 1 min
Impulse voltage 6 kV, 1.2/50 μ s
option: main circuits 12kV (aux. circuits: 6kV)
Short-circuit current 30 I_{max}
EMC: VF interferences (EC 801-4) 6 kV
Optical interface IEC62056-21 (IEC 61107)
Outputs – impulse:	
S0 $t_i = 30$ ms (10, 20, 30, ..., 160 ms)
Dimensions 250 x 178 x 55 mm
Mass 1kg

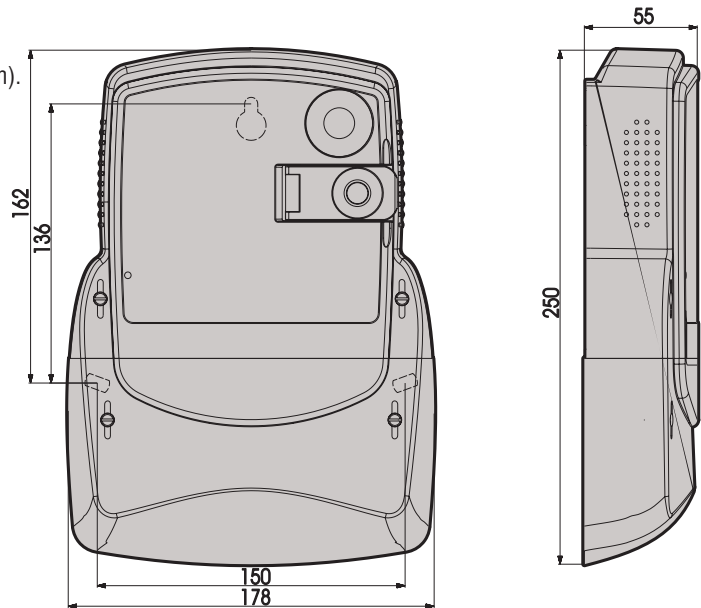

Stephen P. Wales Ltd

The Old Brewery Works, Lr Ellacombe Church Rd,
Torquay. UK. TQ1 1JH

Tel: 01803 295430 Fax: 01803 212819

email: sales@stephenpwales.co.uk